

TYPICAL WET WELL PLAN
N.T.S.

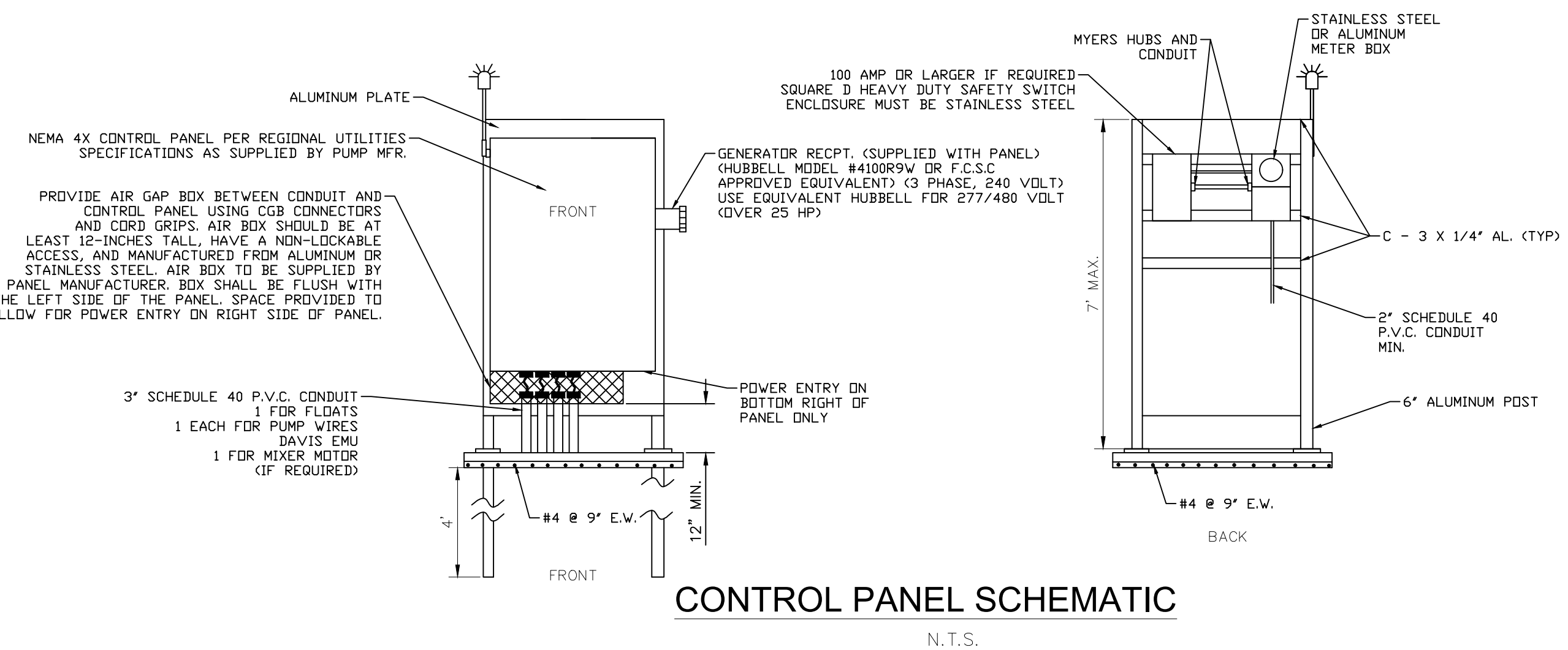

CONTROL PANEL SCHEMATIC
N.T.S.

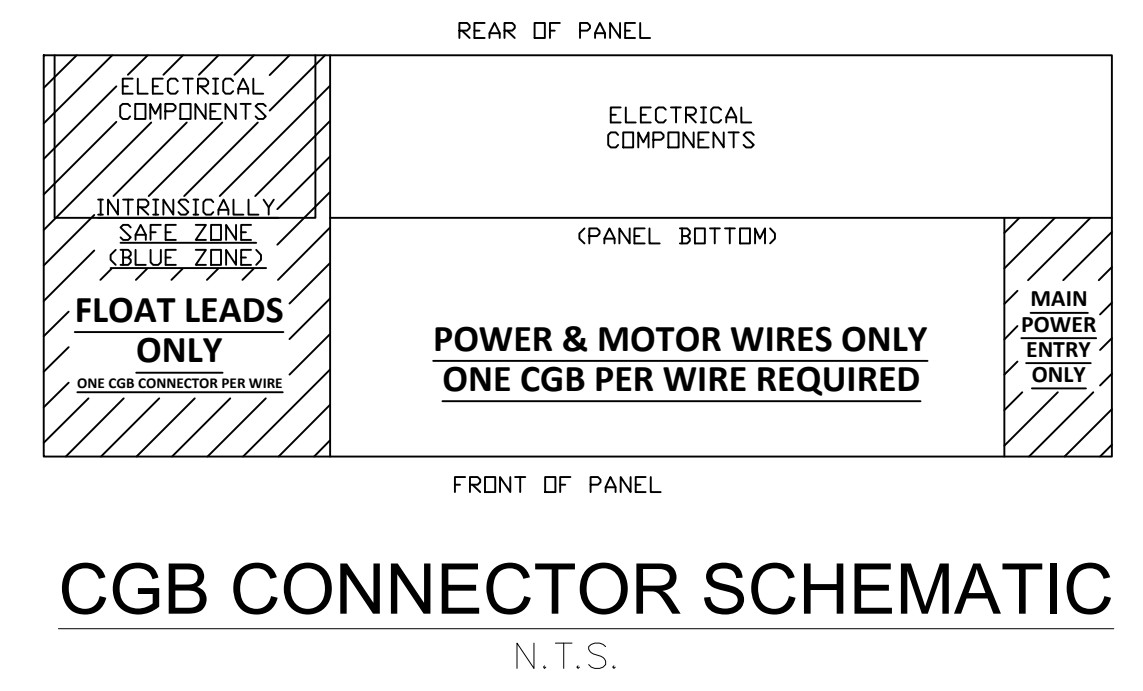

CGB CONNECTOR SCHEMATIC
N.T.S.

APPROVED FOR 2024

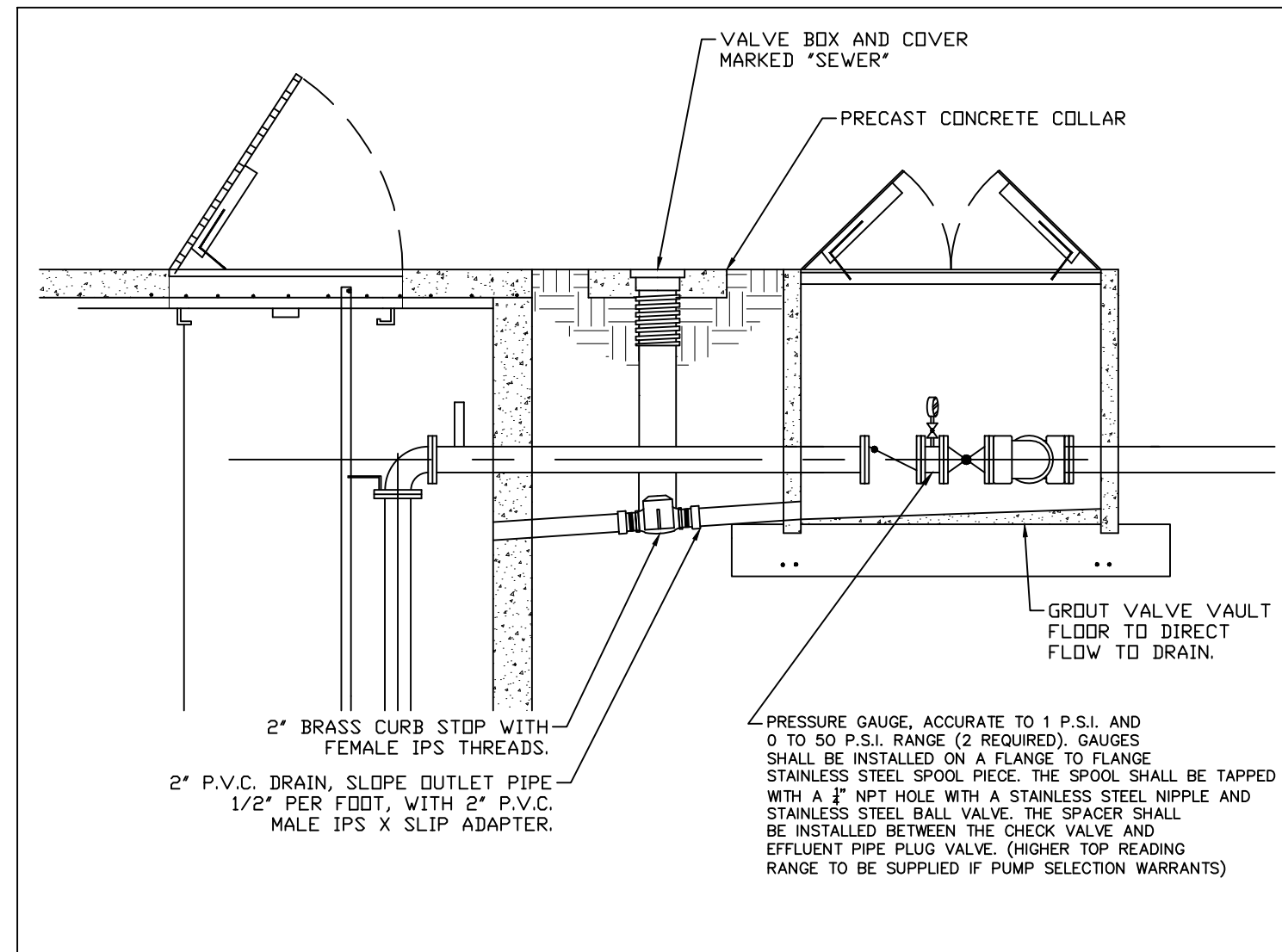

VALVE VAULT DRAIN DETAIL
N.T.S.

GENERAL NOTES:

1. A) VALVE VAULT SHALL BE COATED WITH KOP-COAT COAL TAR EPOXY 300-M INSIDE AND OUT. (TWO COATS, 9 MILS EACH)
2. B) WET WELL SHALL BE COATED WITH KOP-COAT COAL TAR EPOXY 300-M ON THE EXTERIOR ONLY (TWO COATS, 9 MILS EACH) BY FABRICATOR. INTERIOR OF WET WELL SHALL BE COATED WITH 125 MIL OF EITHER RAVEN 405 MOISTURE TOLERANT BLUE EPOXY RESIN, GML COATINGS - GREEN MONSTER, OR QUADEX STRUCTURE GUARD AFTER THE WET WELL HAS BEEN CONSTRUCTED IN PLACE AND PLUMBED. CONTRACTOR SHALL SUPPLY TO REGIONAL UTILITIES, APPLICATOR'S CERTIFICATION TO INSTALL PRODUCT, AS WELL AS WARRANTY SHEETS FROM THE APPLICATOR AND MANUFACTURER. ALL INTERIOR COATINGS SHALL BE FLASH (SPARK) TESTED PER MANUFACTURER'S SPECIFICATIONS AND RESULTS PROVIDED TO REGIONAL UTILITIES.
3. BASE AND FIRST RISER UNIT TO BE CAST MONOLITHIC.
4. VALVE VAULT SHALL BE SIZED TO PERMIT EASY REMOVAL OF CHECK VALVE SPINDLES WITH MINIMUM CLEARANCES AS SHOWN FOR 4" DIAMETER PIPE AND SMALLER CLEARANCES SHALL INCREASE AS REQUIRED FOR LARGER PIPE SIZES, SIZE OF HATCH ON VALVE VAULT IS FOR 4" PIPE AND SHALL INCREASE ACCORDINGLY WITH LARGER PIPE SIZES.
5. ALL LOCATIONS WHERE PIPES ENTER OR LEAVE THE WET WELL OR VALVE VAULT SHALL BE MADE WATERTIGHT WITH WALL SLEEVE OR NON-SHRINK GROUT.
6. THERE SHALL BE NO VALVES OR ELECTRICAL JUNCTION BOXES IN WET WELL.
7. ALL ENCLOSURES SHALL BE NEMA 4X.
8. WET WELL AND VALVE VAULT COVERS SHALL BE ALUMINUM WITH 316 S.S. HARDWARE SIZE AS REQUIRED BY PUMP MANUFACTURER AND APPROVED BY FLORIDA COMMUNITY SERVICES.
9. FLEXIBLE COUPLING SHALL BE SLEEVE TYPE.
10. ALL HARDWARE IN WET WELL AND VALVE BOX TO BE STAINLESS STEEL GRADE 316 OR BETTER
11. ALL EXPOSED FERROUS METAL WITHIN WET WELL AND VAULT SHALL BE COATED WITH KOP-COAT COAL TAR EPOXY 300-M.
12. WET WELLS AND VALVE VAULTS WITHIN THE RIGHT OF WAY OR WITHIN 25 FEET OF ANY ROAD OR IN ANY AREA DEEMED APPROPRIATE BY FCSC SHALL BE REQUIRED TO HAVE TRAFFIC RATED APPROVED ALUMINUM COVERS FOR WEIGHT BEARING.
13. CONTROL PANEL SHALL HAVE BATTERY BACK UP FOR ALARM SYSTEM.
14. ALL MECHANICAL JOINT FITTINGS ON PRESSURE PIPE SHALL HAVE BOTH "MEGALUG" TYPE JOINT RESTRAINING GLANDS AND THRUST BLOCKS.
15. THE CONTRACTOR IS RESPONSIBLE FOR OBTAINING AND MEETING THE REQUIREMENTS OF REGIONAL UTILITIES STANDARD DETAILS AND SPECIFICATIONS LATEST EDITION.
16. ANY LOCATION WHERE PRESSURE PIPELINE CURVATURE EXCEEDS MANUFACTURER'S SPECIFICATIONS, APPROPRIATE MECHANICAL JOINT FITTINGS SHALL BE USED.
17. ALL 2-INCH VALVES SHALL BE BALL TYPE - 2-INCH GATE VALVES SHALL NOT BE USED.
18. ALL TIE IN TO EXISTING PRESSURIZED PIPELINES SHALL BE BY TAPPING SLEEVE (3 INCH TAP AND LARGER) (OR TAPPING SADDLE, 2 INCH TAP AND SMALLER) AND VALVE.
19. DEVELOPERS OF PRIVATE PROJECTS SHALL PROVIDE ALL WETLANDS PERMITS NECESSARY FOR UTILITY CONSTRUCTION.
20. ALL DUCTILE IRON PIPE SHALL BE COATED INSIDE AND OUT WITH PROTECTO 401 CERAMIC EPOXY.
21. A MIXER SHALL BE INSTALLED IN ALL CONCRETE WET WELLS LARGER THAN 6 FOOT DIAMETER. THE MIXER SHALL BE A WILCO SUBMERSIBLE MIXER OR APPROVED EQUAL
22. ALARM LIGHT SHALL BE VISIBLE ABOVE ANY AND ALL OBSTRUCTIONS.
23. LEVEL MEASUREMENT PROBE (LMP) #61-10-50 OR #97-10-50, ALONG WITH CONVERTER #LPC420R-RM TO BE USED AS PRIMARY LEVEL CONTROL, WITH FLOATS AS BACKUP.

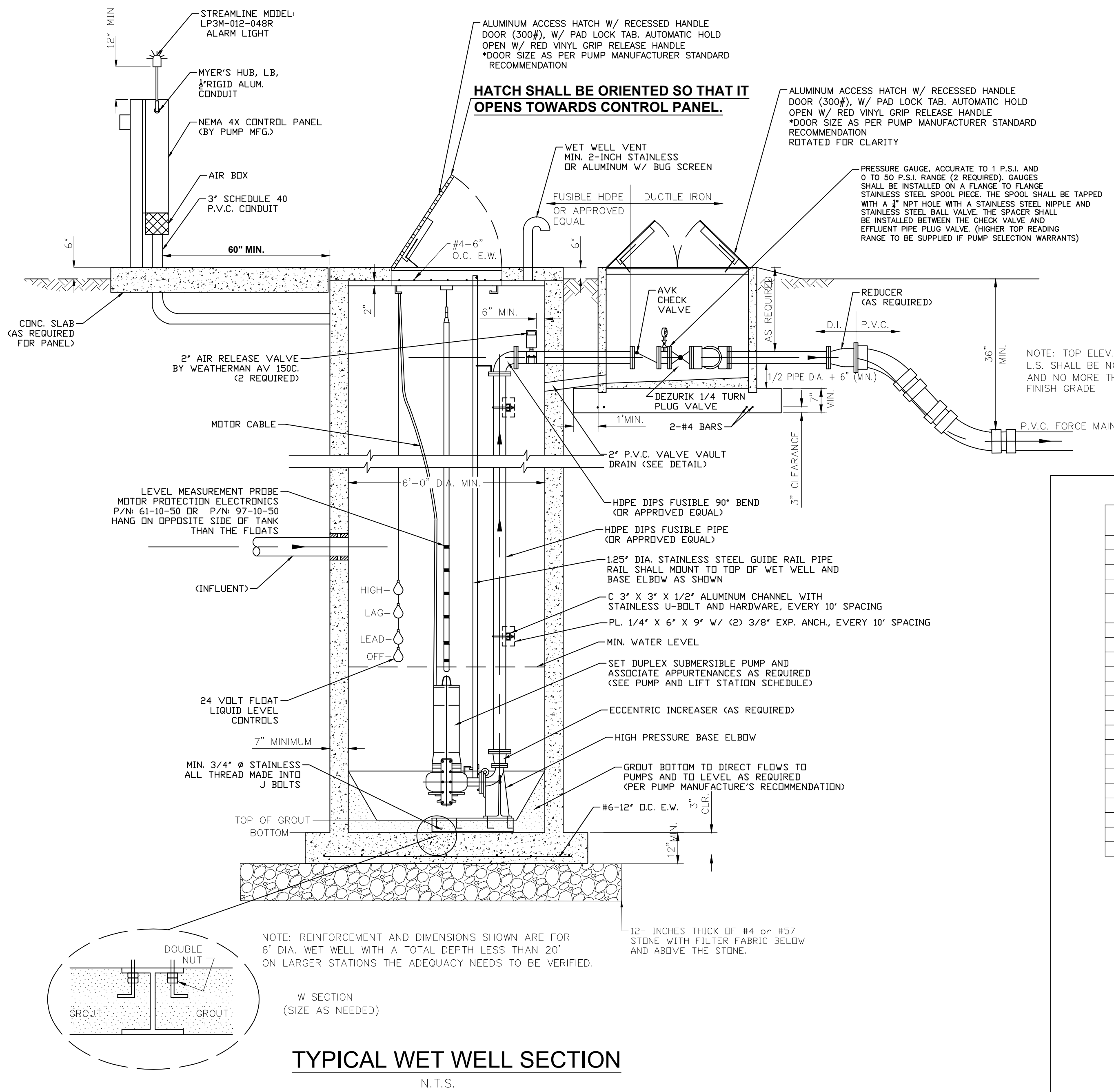

TYPICAL WET WELL SECTION
N.T.S.

PUMPING STATION DATA	
Project Name	MLC
Pump model	
Motor model	
Impeller size	
Voltage (3 PHASE)	<25HP 120/208/240 volts > 25HP 277/480 volts
h.p.	
r.p.m.	
delivery, gpm (High System Head)	
delivery, gpm (Low System Head)	
TDH, feet (High System Head)	
TDH, feet (Low System Head)	
Influent elev.	
High level alarm elev.	
Log pump on elev.	
Lead pump on elev.	
Low level alarm elev.	
Both pumps off elev.	
Bottom elev.	
Force main dia.	
Wet well dia.	

NOTE: VERIFY VOLTAGE AND PHASE AVAILABILITY WITH ELECTRIC COMPANY PRIOR TO ORDERING EQUIPMENT.

WET WELL MINIMUM WALL THICKNESS TABLE	
DIAMETER	MIN. WALL THICKNESS
6"	7"
7"	8"
8"	9"

PUMPING STATION DATA

REVISION

APPR.

DATE

NO.

REGIONAL UTILITIES
OPERATED BY FLORIDA COMMUNITY SERVICES
CORPORATION OF WALTON COUNTY INC.

4432 HWY 98 EAST
SANTA ROSA BEACH, FL 32459

Phone: (850) 231-5114
Fax: (850) 231-4924

PROJECT NAME:

SHEET TITLE: **LIFT STATION (NON-CLOG PUMPS) CONCRETE STANDARD DETAIL**

SCALE:

DRAWN BY: **RT & WK** CHECKED BY: **RAD**

PROJECT NO.: **000-000**

DRAWING SCALE: **N.T.S.**

PLOT DATE:

SHEET NO. **1** OF **1**

SHEET: **LS-C**