

1 **LOW PRESSURE SERVICE**
N.T.S.

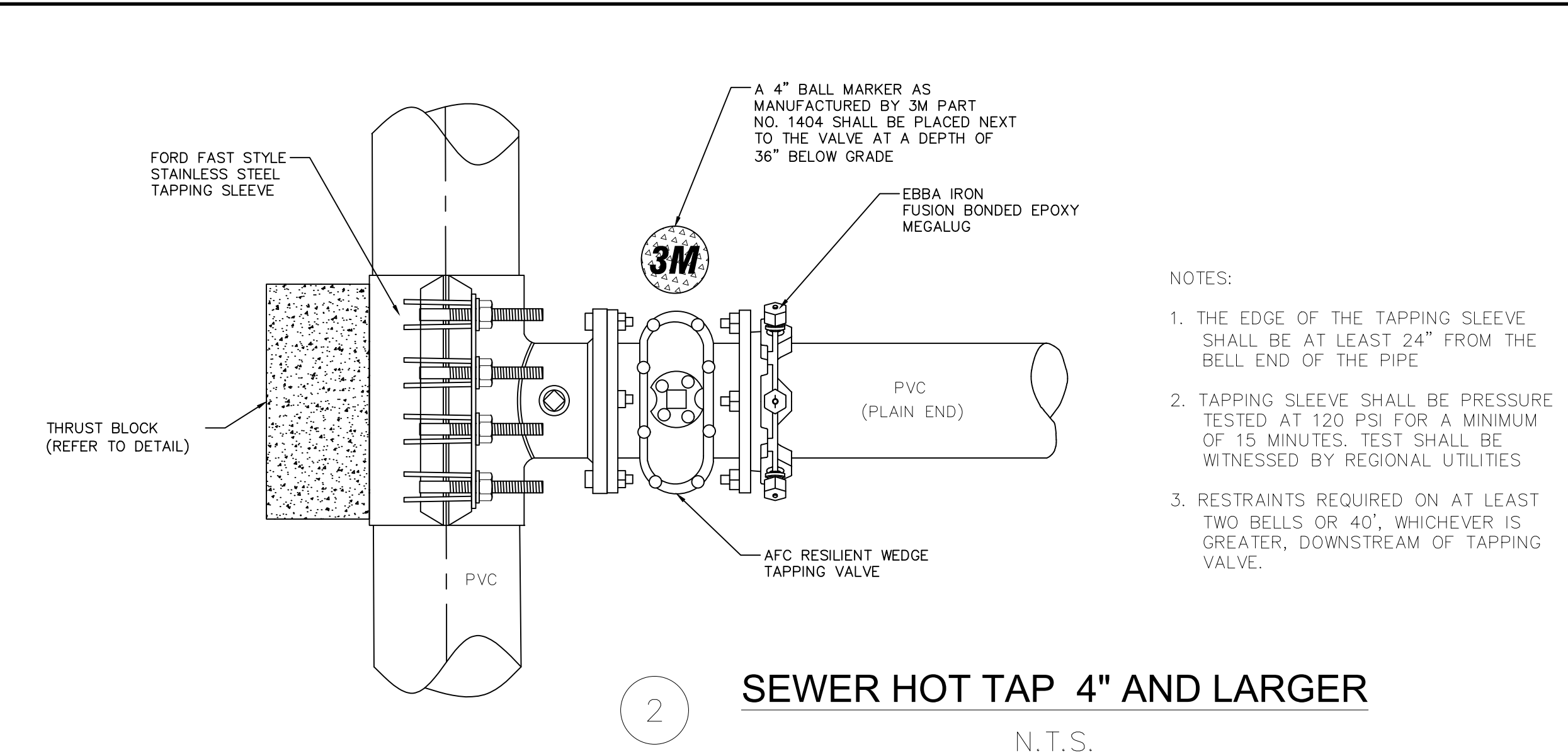

2 **SEWER HOT TAP 4\"/>**

- BEDDING DETAIL NOTES:**
- THE BACKFILL TO A POINT TWELVE (12) INCHES ABOVE THE PIPE SHALL BE PLACED BY HAND AND SHALL BE CAREFULLY SELECTED MATERIAL FREE FROM ROCKS, BOULDERS, CLODS, ORGANIC MATERIAL, OR OTHER DEBRIS AND LIGHTLY COMPACTED PRIOR TO PLACING REMAINING BACKFILL. THE BALANCE OF THE BACKFILL MAY BE PLACED IN THE DITCH BY HAND OR BY MECHANICAL EQUIPMENT. NO BACKFILL SHALL BE DROPPED DIRECTLY ONTO EXPOSED PIPE.
 - CONTRACTOR SHALL EMPLOY AN EXCAVATOR-MOUNTED TRENCH ROLLER OR OTHER MECHANICAL COMPACTION EQUIPMENT TO PROVIDE BACKFILL DENSITIES OF 95% OR GREATER AT ±2% OPTIMUM MOISTURE CONTENT. SURFACE FLOODING AND WATER JETTING OF BACKFILL SHALL NOT BE PERMITTED FOR BACKFILL CONSOLIDATION.
 - ALL BACKFILL SHALL BE IN ACCORDANCE WITH SECTION 3.0 OF REGIONAL UTILITIES CONSTRUCTION SPECIFICATIONS.
 - PIPE COVER SHALL NOT BE LESS THAN 36 INCHES, NOR GREATER THAN 48 INCHES EXCEPT WHERE SPECIFICALLY SHOWN ON THE CONSTRUCTION DRAWINGS AND APPROVED BY REGIONAL UTILITIES.

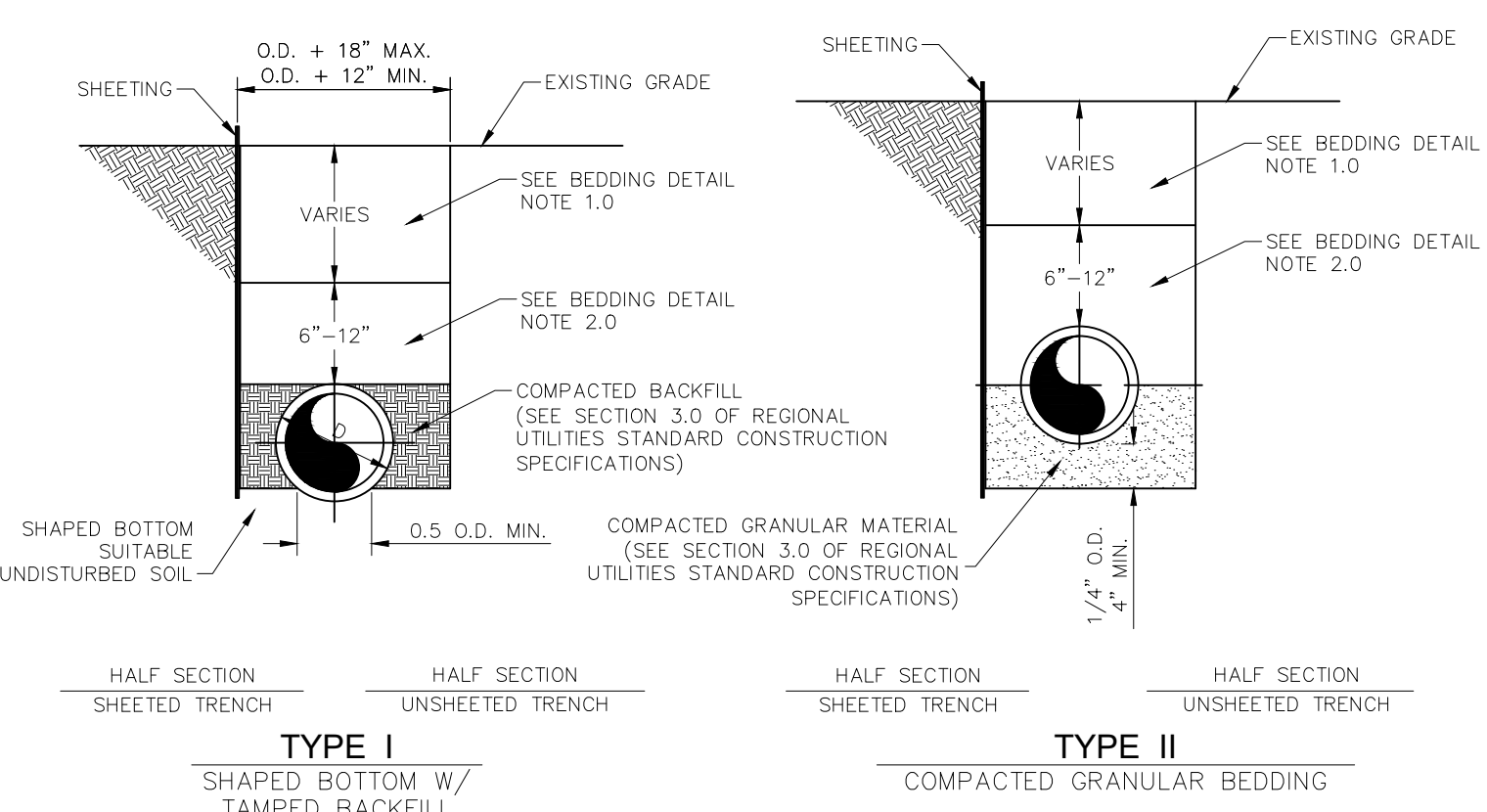

3 **TYPICAL BEDDING DETAIL**
N.T.S.

PRESSURE SEWER GENERAL NOTES:

- ALL MECHANICAL JOINT FITTINGS ON PRESSURE PIPE SHALL HAVE BOTH "MEGALUG" TYPE JOINT RESTRAINING GLANDS AND THRUST BLOCKS.
- THE CONTRACTOR IS RESPONSIBLE FOR OBTAINING AND MEETING THE REQUIREMENTS OF REGIONAL UTILITIES STANDARD DETAILS AND SPECIFICATIONS LATEST EDITION.
- ANY LOCATION WHERE PRESSURE PIPELINE CURVATURE EXCEEDS MANUFACTURERS' SPECIFICATIONS; APPROPRIATE MECHANICAL JOINT FITTINGS SHALL BE USED.
- ALL 2-INCH VALVES SHALL BE BALL TYPE - 2-INCH GATE VALVES SHALL NOT BE USED.
- ALL TIE IN TO EXISTING PRESSURIZED PIPELINES SHALL BE BY TAPPING SLEEVE (3 INCH TAP AND LARGER) (OR TAPPING SADDLE, 2 INCH TAP AND SMALLER) AND VALVE.
- DEVELOPERS OF PRIVATE PROJECTS SHALL PROVIDE ALL WETLANDS PERMITS NECESSARY FOR UTILITY CONSTRUCTION.
- ALL MANHOLES SHALL HAVE FINISHED GRADING AROUND THEM FOR PROTECTION PRIOR TO ACCEPTANCE BY REGIONAL UTILITIES.
- ALL SEWER MAINS SHALL BE COVERED TO FINISH GRADING FOR PROTECTION PRIOR TO ACCEPTANCE BY REGIONAL UTILITIES.
- LOCATOR BALLS PER SPECIFICATIONS SHALL BE REQUIRED AT ALL FORCE MAIN VALVE LOCATIONS.
- JOINT RESTRAINTS SHALL BE REQUIRED ON ALL FORCE MAINS LOCATED IN PAVED AREAS.
- ALL CONSTRUCTION SHALL BE IN ACCORDANCE WITH REGIONAL UTILITIES' WRITTEN SPECIFICATIONS, LATEST EDITION.
- AT ALL HIGH POINTS CRESTED DURING FORCE MAIN CONSTRUCTIONS, AIR RELEASE VALVES SHALL BE CONSTRUCTED.
- CTS TUBING SHALL ONLY BE USED FOR LOW-PRESSURE GRINDER SERVICES.
- ALL GRINDER SERVICES SHALL BE PRESSURE/FLOW TESTED.
- PRIOR TO A FINAL INSPECTION, ALL LOT CORNERS SHALL BE STAKED BY THE SURVEYOR. INSPECTOR WILL NOT PERFORM FINAL INSPECTION IF STAKING IS INCOMPLETE.

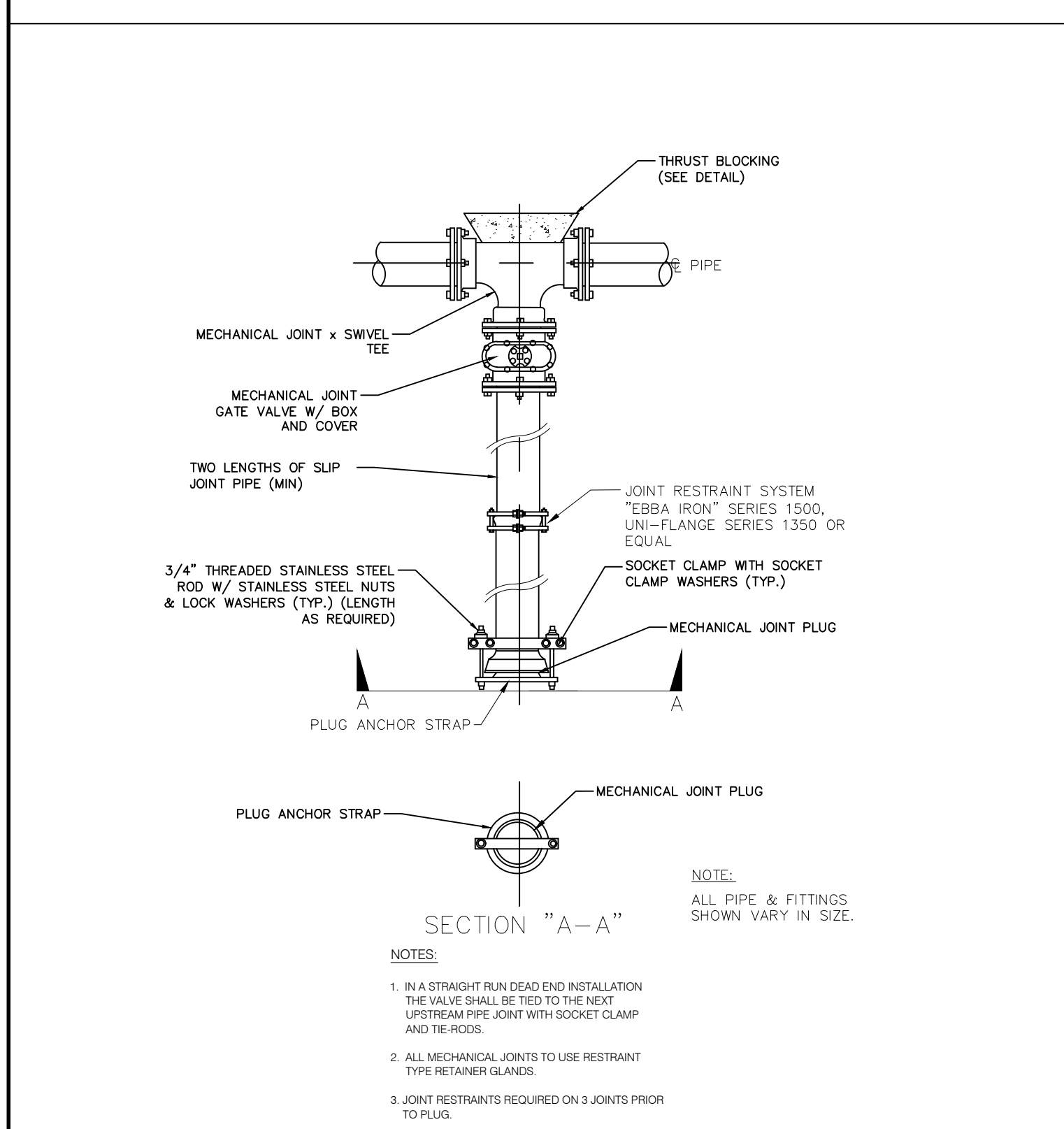

4 **DEAD END STUB DETAIL**
N.T.S.

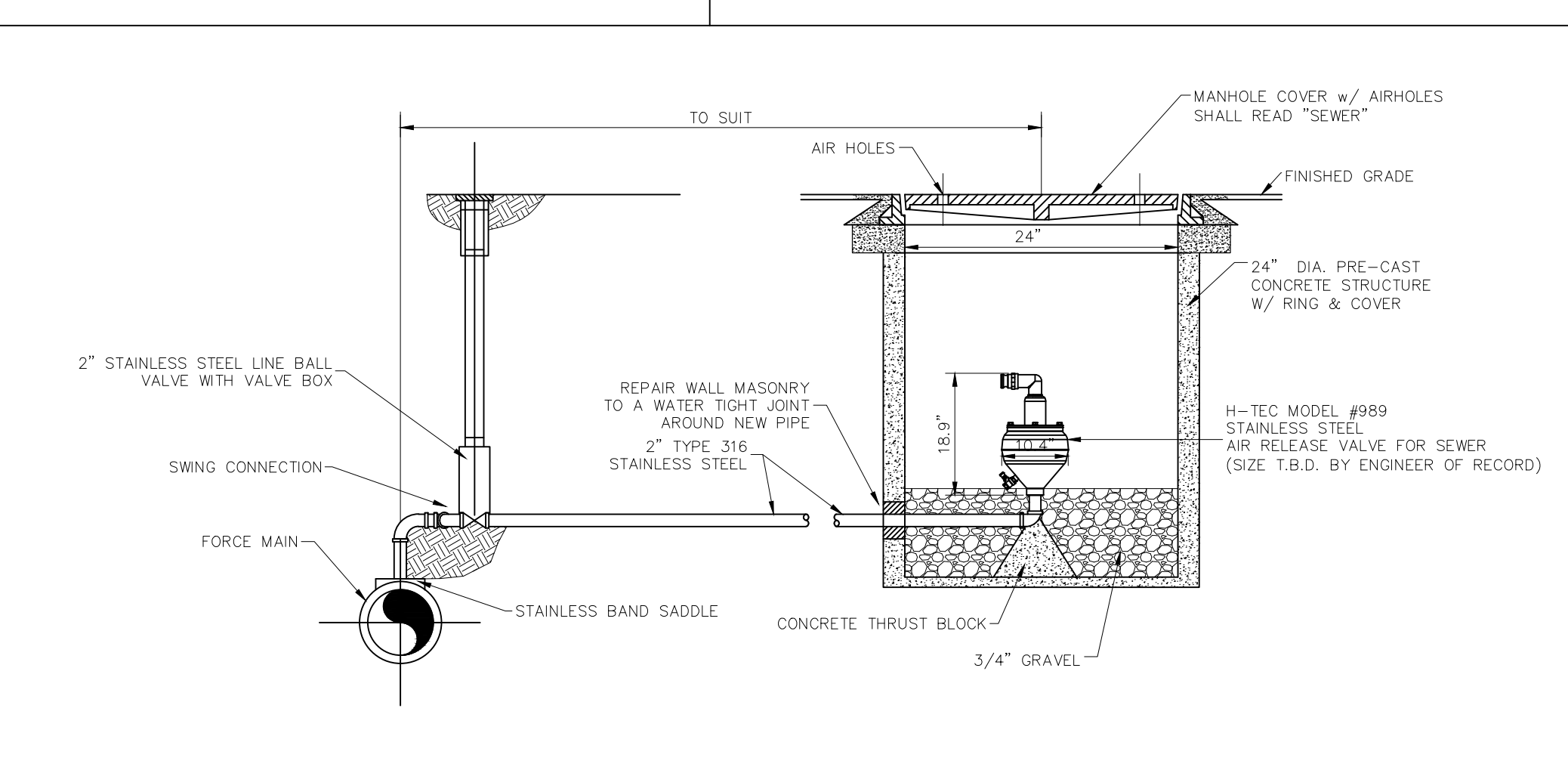

5 **TYPICAL AIR AND/OR VACUUM VALVES**
N.T.S.

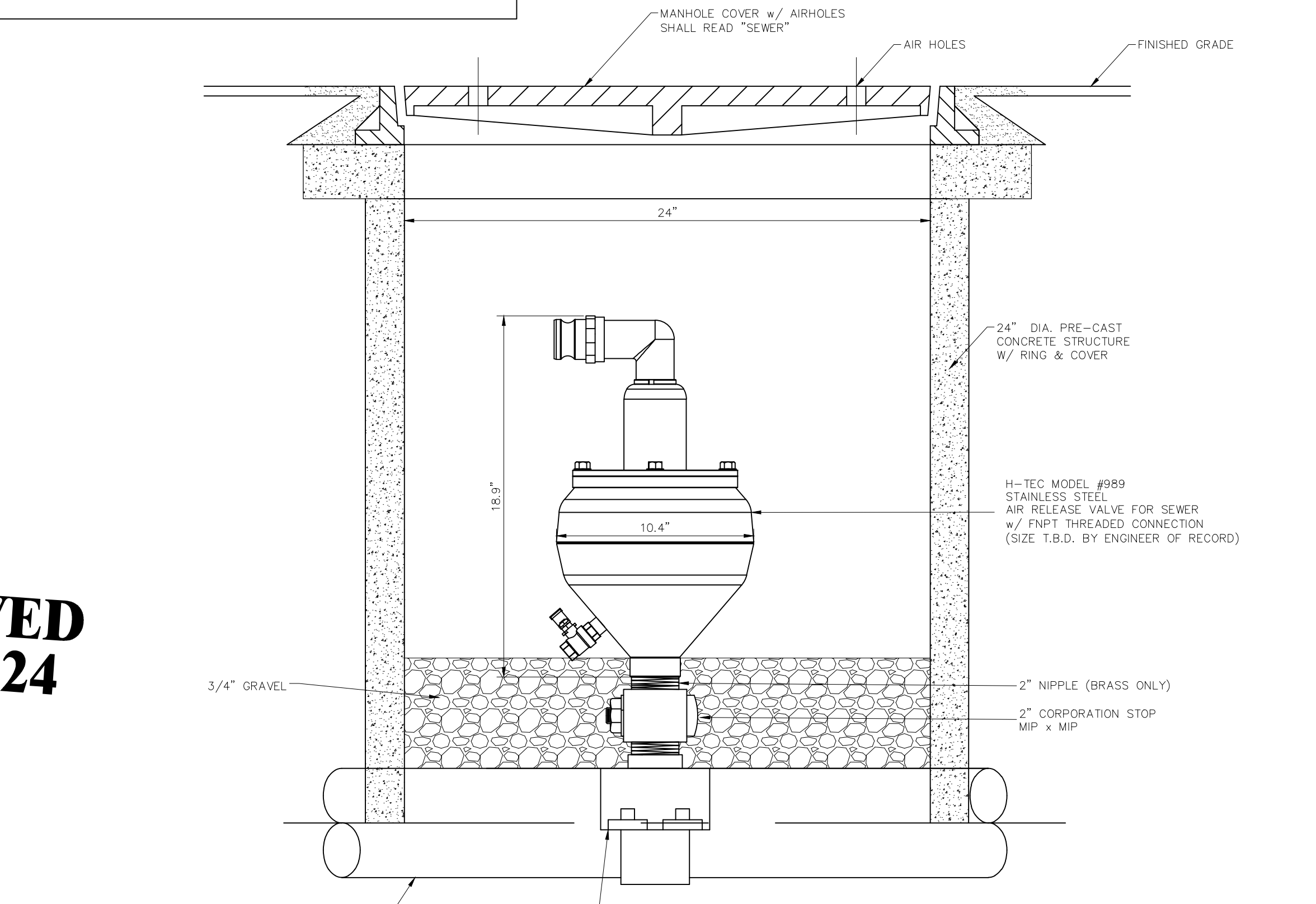

6 **TYPICAL PRESSURE SEWER AIR RELEASE MANHOLE**
N.T.S.

APPROVED FOR 2024

NO.	DATE	APP'R.	REVISION

REGIONAL UTILITIES
OPERATED BY FLORIDA COMMUNITY SERVICES CORPORATION OF WALTON COUNTY INC.
4432 HWY 98 EAST
SANTA ROSA BEACH, FL 32459
Phone: (850) 231-5114
Fax: (850) 231-4924

AUSTINWOOD LN WATER & SEWER EXTENSION
PROJECT NAME:
PRESSURE SEWER STANDARD DETAILS
SHEET TITLE:

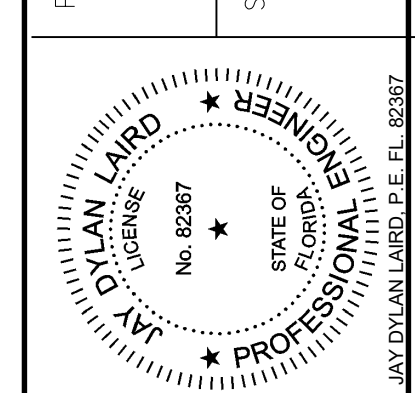

DRAWN BY:	CHECKED BY:
RT	RAD
PROJECT NO.:	222-014
DRAWING SCALE:	N.T.S.
PLOT DATE:	Mar. 9, 2023
SHEET NO. OF 9	5 OF 9
SHEET:	PS-1